

**SCOPE OF WORK
FOR
FORBESTOWN DITCH TO PIPELINE
REPLACEMENT PROJECT**

**Prepared for:
North Yuba Water District
8691 La Porte Road
Brownsville, California 95919**



**111 Mission Ranch Blvd. Ste. 100
Chico, CA 95926**

September 2019

Table of Contents

| | |
|--|----|
| 1. PURPOSE AND SCOPE | 4 |
| 2. BACKGROUND | 5 |
| 2.1 Ditch History | 5 |
| 2.2 Communities Served | 6 |
| 3. PRELIMINARY BASIS OF DESIGN | 7 |
| 3.1 Design Flow | 7 |
| 3.2 Project Alignment | 7 |
| 4. ALTERNATIVES EVALUATION..... | 8 |
| 4.2 Geotechnical Review and Design | 9 |
| 4.2.1 Take no significant action | 9 |
| 4.2.2 Horizontal Drains | 9 |
| 4.2.3 Plate Piles | 9 |
| 4.2.4 Pipeline Supports | 10 |
| 4.2.5 Soil Nails..... | 10 |
| 4.2.6 Buttress Stabilization | 10 |
| 4.2.7 Recommendation | 10 |
| 4.3 Pipe Installation | 10 |
| 4.3.1 Pipe Material | 10 |
| 4.3.2 Pipe Installation Method | 11 |
| 4.3.3 Recommendation | 13 |
| 4.4 Existing Channel Drainage | 14 |
| 4.4.1-Tributary Drainage..... | 15 |
| 4.4.2 Sheet Flow Drainage..... | 15 |
| 5. MAINTENANCE REQUIREMENTS | 15 |
| 5.1 Maintenance Access..... | 15 |
| 5.2 Pipe Flow Turn out | 16 |
| 5.3 Pipe Access Port | 16 |
| 6. ENVIRONMENTAL REVIEW | 16 |
| 7. DESIGN & CONSTRUCTION SCHEDULE | 17 |

Exhibits

Exhibit A: Location Map

Exhibit B: Preliminary Construction Plans (available at the NYWD Office, 8691 La Porte Rd, Brownsville, CA 95919)

Exhibit C: Preliminary Engineering Geological Observation and Alternatives

Exhibit D: Probable Construction Cost

1. PURPOSE AND SCOPE

The North Yuba Water District (NYWD) receives surface water diverted from the South Fork of the Feather River that is conveyed via the Forbestown Ditch to a water treatment facility, from which water is conveyed to the surrounding communities of Challenge, Brownsville, Rackerby and Forbestown. This water conveyance facility was originally constructed in the 1860s and NYWD depends on this water supply to provide treated potable supplies and irrigation water to customers in the District's service areas. NYWD's raw water conveyance infrastructure has deteriorated over the years and currently does not meet operational requirements. This open and unlined conveyance system is susceptible to both natural and human-caused pollutants, vandalism, damage due to fire, unauthorized withdrawals, and significant water losses. The District is governed by a five-member Board of Directors, and the Board has prioritized the preliminary engineering on the Forbestown Ditch to Pipeline Replacement Project, as the renewal of existing water rights are pending demonstration by the District that they can eliminate, or significantly curtail, the substantial water losses through the Ditch conveyance.

NYWD's ongoing goal is to improve the existing conveyance system and increase its efficiency by reducing raw water losses and minimizing the opportunity for contaminants to enter the conveyed water. The District has been actively seeking grant funding to support this effort, and under Funding Agreement No. D17-02033 with the California State Water Resources Control Board (SWRCB), Project No. 5810003001P, NYWD obtained funds to conduct a preliminary engineering review and design work, including the following tasks:

- Task 1 - Project Evaluation and Pre-Design Engineering
- Task 2 - Pre-Design Geotechnical and Surveying
- Task 3 – Preliminary Engineering Update and Engineering Report
- Task 4 - CEQA/NEPA Documentation
- Task 5 - Plans, Specifications and Estimates (PS&E)
- Task 6 - Project Management

NorthStar has been retained by NYWD to review the existing site condition and the previous feasibility studies listed below to determine the best viable option in mitigating any known operational and maintenance issue in conformance with the above outlined tasks.

- North Yuba Water District Forbestown Ditch Improvement Feasibility Study, dated November 5, 2009.
- Preliminary Engineering Evaluations for Raw Water Conveyance Systems in the North Yuba Water District, dated September 25, 2015.

NYWD has worked continually during the preliminary engineering review and design phases to seek out additional funding sources for the construction phase of this project. The District understands how critical it is to focus on completing all tasks for the SWRCB planning project and intends to proceed with the construction application and apply for any other available funding sources, including through the IRWM Program process. The District has also had multiple consultations with the USDA regarding the preparation of a Preliminary Engineering Report (PER), which better positions the District to apply for grant and/or loan funds as they become available.

2. BACKGROUND

The Forbestown Ditch is owned and operated by NYWD as a component of a much larger water conveyance and distribution system owned by SFWPA. Water is stored in multiple upstream reservoirs for consumptive and non-consumptive uses and water diverted to Forbestown Ditch is utilized by both NYWD and SFWPA. In 2011, SFWPA transferred all right and title of the Forbestown Ditch by Quit Claim Deed to NYWD.

NYWD is closely tied into the South Feather Water & Power Agency's (SFWPA) water delivery system. SFWPA was originally organized as Oroville Wyandotte Irrigation in November 1919. NYWD was originally formed as Yuba County Water District on June 30, 1952 pursuant to water district law. The two districts operate in partnership for conveyance of water owned through respective pre-1914 water rights for both domestic and agricultural supply and generation of hydroelectric power.

2.1 Ditch History

The origins of the Forbestown Ditch date back to the 1850s Gold Rush when it was constructed to divert water from the Feather River to gold mining encampments from high along the western slope of the Sierra Nevada all the way to Oroville. By the end of World War I mining operations had faded away and more and more people began to move into the Feather River canyon and surrounding areas where the water was then used for agricultural and domestic purposes.

The water-right permits and licenses that the District has are the following:

- Water Right Permits 11516 & 11518 – These permits allow for diversion and use of up to a total of 23,700 AFY of water by the District.
- Water Right License 12984 – This water right license authorizes the direct diversion of water from natural Dry Creek flows at rates up to 21.4 cfs, with a maximum of 6,060 AFY during the period of April 1 to October 15 of each year. A bypass flow of 4 cfs must be maintained when water is diverted under this license.
- Statement of Water Diversion & Use No. S022701 (Pre-1914 claim) – This claim allows for the direct diversion of water from Oroleve Creek for the purposes of agricultural irrigation.

The existing North Yuba Water District (NYWD) Forbestown Ditch was constructed in 1865 in native soil. The total length of the Forbestown ditch extends approximately 10 miles. The upper section includes eight (8) miles of the ditch that begins at the Woodleaf Penstock South Fork gauging station 14 (SF 14) and ends at the inlet of Costa Creek Siphon. This section, for the most part, meanders parallel to the natural topographic contours. Approximately 1.5 miles downstream from the head of Forbestown Ditch, water diverted from Oroleve Creek is introduced for irrigation uses. The lower section includes two (2) miles of the ditch that begins at the outlet of Costa Creek Siphon that runs through several private residential areas and ends at the Water Treatment plant, located in Forbestown. See Exhibit A for Location Map. Agricultural supplies are routed from the Forbestown Ditch, through Dry Creek, and into the Dobbins Oregon House Canal. As per the 2005 *Agreement between South Feather Water and Power Agency and Yuba County Water District* (2005 Agreement), NYWD is required to maintain a ditch capacity of 24 cfs for the Districts' use and to provide SFWPA with 11 cfs upon request.

The existing open channel from SF14 to Costa Creek Siphon inlet consists primarily of a side hill channel constructed by completing high side excavation, which was side cast and compacted to provide a low side embankment berm. In general, the resulting trapezoidal ditch consists of a four-foot-wide bottom with 1:1 side slopes and is approximately four feet in depth. The low side berm has an approximate top width of four feet with an approximate 2:1 downhill embankment fill slope. Along this existing alignment include several wood flume, culvert and siphons.

This portion of the ditch is extremely vulnerable to slope instability and overtopping during severe storm events. Through the years, several failures and areas of distress have occurred along the Forbestown Ditch that have caused water conveyance to be disrupted or stopped completely. The most recent failure occurred during the 2017 major storm event during extended and intense rainfall periods which created a completely saturated state and caused significant damage to the ditch at two different locations.

In addition to storm related emergencies that can overwhelm the delivery system, another significant risk associated with the open and unlined channel are water losses due to surge flows that are unable to be used during storm events, significant leakage, evaporation and unpermitted diversions. It is estimated that upwards of 50-70% of flows are lost to leakages and evaporation respectively.

Two (2) miles of the unlined ditch from Costa Creek Siphon outfall to the Water Treatment Plant runs through a residential area and is generally constructed as a trapezoidal ditch that consists of a four-foot-wide bottom with 1:1 side slopes and is approximately four foot in depth. The soil at this portion of the ditch is stable, however, the system is still susceptible to water loss due to unpermitted diversion and evaporation.

Another main issue associated with the current condition of the ditch is degraded water quality. An open channel can be affected by a variety of issues such as accumulating and decomposing vegetation from the surrounding areas and native species animal waste which can cause introduce bacterial contamination.

2.2 Communities Served

The NYWD is a community water system providing domestic and agricultural water to the communities of Challenge, Brownsville, Rackerby and Forbestown. NYWD relies solely on surface water for its supplies, which are diverted from the South Fork of the Feather River and conveyed via the Forbestown Ditch to a water treatment facility, from which water is distributed throughout the service area. Forbestown Ditch is located in Yuba (and portions of Butte) County, beginning near the community of Woodleaf. Approximately 3,100 people are serviced by the District via 785 service connections. Of these, 119 connections (with only 114 currently active) are for irrigation water, the remaining are domestic service connections. In 2018, a Median Household Income survey of customers was conducted, and the results certified that the District service area qualifies as a severely disadvantaged community. This designation will assist the District in obtaining priority grant funding.

3. PRELIMINARY BASIS OF DESIGN

The Forbestown ditch was constructed in 1865 as a water conveyance system and has been in service for over 150 years. In the recent years, the ditch has experienced several failures, severe water losses and contamination which affects the efficiency and reliability of the system. NorthStar has reviewed the different alternatives and selected the most feasible alternative based on constructability, ease of maintenance and cost. We are proposing that the conveyance system be enclosed through 42-inch ADS N-12 pipe. The upper section will be installed at grade and supported by pipe anchor blocks while the lower section shall be installed below grade with a minimum of 1 foot of backfill materials and pipe anchoring system. See Exhibit D for probable construction cost of the recommended alternative.

The recommended design alternative in this report provides not only a cost-effective solution in mitigating any issues with the existing ditch, once constructed, it will also increase efficiency and reliability of the conveyance system by reducing bacteria and aluminum contaminations, and water loss caused by failures, leaks and unpermitted diversion. In preparing the Preliminary Construction plans, NorthStar was mindful of all applicable state and federal laws, rules and regulations, and local ordinances.

3.1 Design Flow

Based on the data provided by NYWD, the Preliminary Engineering Evaluations and Report completed by Forsgren Associates, Inc. dated September 25, 2015, along with input provided by Sage Engineering during the peer design review, a flow of approximately 24 cubic feet per second (cfs) was used as a basis in determining the required diameter of pipe with a recommendation of utilizing 42-inch diameter pipe to convey the design capacity. The Revised Hydraulic Analysis, which includes recommended revisions by Sage Engineering, is available upon request.

3.2 Project Alignment

The proposed alignment for the pipe line will also match the existing ditch. This will reduce the cost of obtaining new easements and reduce the amount of area being disturbed by utilizing the existing structures and improvement such as the wood flumes, CMP/ADS N-12 pipes and siphons. These existing structures will remain and only minor modifications will be required for conformance. Preliminary Construction Plans are included in Exhibit B.

4. ALTERNATIVES EVALUATION

NorthStar has studied the following alternatives proposed in the previous technical studies conducted in 2009 and 2015, along with the currently proposed project:

- Lining the open-channel raw-water conveyances;
- Realignment of the existing conveyance;
- Piping and burying the full 10 miles of the Forbestown Ditch; and
- Convert to pressurized pipe after the Costa-Creek Turn-out.

ALTERNATIVE #1 –No Action alternative

Severe weather is a well-documented seasonal occurrence that will continue to occur annually in Yuba County. Damage and disaster declarations related to severe weather have occurred and will continue to occur in the future. Heavy rain, thunderstorms, wind, extreme temperatures and even tornadoes are frequent severe weather occurrences in the County. Actual damage associated with the primary effects of severe weather has been limited, however, it is the secondary hazards caused by weather, such as floods, fire, and agricultural losses, infrastructure damage that have had the greatest impact on the County. NYWD does not have documentation of heavy storm damage on an annual basis, but there is the potential for the NYWD to begin feeling the effects of climate change, with increased uncertainty for heavy storm events, they may begin sustaining high cost annual damages if this project is not implemented. Additionally, the future renewal of water diversion permits could be hindered because of the significant ongoing water losses throughout the Forbestown Ditch.

ALTERNATIVE #2 - Proposed Action

The above Scope of Work outlines the proposed construction project. This option was selected because it provides a soundly engineered solution to stabilize the most recent section of failure. The Forbestown Ditch to Pipeline Replacement Project is a priority for the communities served within the NYWD service area because they are predominantly disadvantaged communities that do not have the means to provide alternative water, even temporarily, for domestic, agricultural or fire suppression supplies. This project was selected because of all alternatives considered, it provides both the best financial option, but also minimizes soil and environmental disturbances, provides sound engineering design, and will not interrupt service to customers during construction.

ALTERNATIVE #3 – Previously listed alternatives

Alternative designs included:

Fully encasing the Forbestown Ditch and burying the pipe within the current alignment. This alternative design was eliminated due project costs related to soil importation, construction feasibility, and concerns with hydrostatic pressure uplift causing the pipe to float.

Lining the Forbestown Ditch was considered to provide an alternate cost-effective solution to the existing Forbestown Ditch, a concrete cloth was also considered for lining the Ditch. The roll is quick to install and flexible enough to conform to different curves and ditch profiles. Although the cloth rapidly forms into a waterproof concrete ditch

within twenty-four hours, exposure to the atmosphere does not relieve the NYWD from water quality issues, liability and maintenance concerns.

Pressurized pipe was eliminated because it would require cast iron piping to hold the pressure, and this design option is cost prohibitive.

Alternative locations examined included the entire length of Forbestown Ditch starting at the Woodleaf Penstock Turnout and traveling to the Water Treatment Plant within Forbestown. This alternative was eliminated due to project costs and construction feasibility.

Alternative materials such as steel pipe and concrete have the disadvantage of being delivered to the job site in a customized pre-fabricated state, and therefore require a semi-tractor trailer for delivery, larger access and staging points and heavy equipment required to place the pipe. Due to the remote location and terrain, these materials costs would significantly increase the installation costs, thereby eliminating these as material options.

4.2 Geotechnical Review and Design

Vertical Science, Inc, as a part of this report, was retained by NorthStar Inc. to provide a geological observation of the two areas of recent soil failure and provide alternatives to stabilize the soil below the ditch.

The report provided by Vertical Science, Inc, shows that the recent failures may have been results of the ditch being adversely affected by slope creep and shallow slope failures. These types of soil instabilities and failures occurs in areas with relatively steep slopes and high Plasticity Index (PI). Several alternatives below were provided by Vertical Science, Inc to mitigate the issue:

4.2.1 Take no significant action

This alternative involves taking no significant actions to improve the slope stability. Soil saturation was the main reason for the ditch failure that resulted to the emergency repair project in 2017. Enclosing the conveyance system with the pipeline will reduce the amount of water that penetrates through the soil below the existing ditch. This will ultimately increase the stability of the of the ditch and prevent future slope failures.

4.2.2 Horizontal Drains

As stated in the report, horizontal drains consist of perforated pipelines that are installed with the inclination of 2 to 5 degrees into the slope. These pipelines are designed to capture any subsurface water below the ditch and divert it away from the slope to reduce soil moisture and increase slope stability.

4.2.3 Plate Piles

Plate piles are another alternative that can be effective in stabilizing soil cause by slope creep. As per the report, it consists of a proprietary pile system where a flat plate is welded onto a narrow-diameter pipe pile that is then driven into the soil of the affected area.

4.2.4 Pipeline Supports

Pipeline support includes construction of foundations that extends 15 feet below grade. This will resist the lateral forces imposed by the creeping soils and prevent the pipe from moving.

4.2.5 Soil Nails

Soil nails can be done in two different methods. A conventional method which includes steel rods or tendons installed into a slope then grouted in place or a launched soil nails where a steel rods are launched up to 20 feet deep by using a compressed air canon.

4.2.6 Buttress Stabilization

Buttress stabilization involves removing landslide deposit to a target depth, installation of subsurface drainage, then reconstruction of the area with engineered fill. This will require heavy equipment during construction.

4.2.7 Recommendation

Based on the initial review of the alternatives and the cost provided by Vertical Science, Inc, NorthStar has determined that the most feasible option in reducing slope instabilities is to take no significant action regarding slope stabilization. It is our understanding, based on the observation of the recent failures, that instabilities are caused by a combination of constantly saturated soil below the berm and steep side slopes. This can be minimized by enclosing the conveyance system with the pipeline to reduce the water that penetrates through the ground that causes the soil to be saturated. Thus, increasing the stability of the berm. The Preliminary Engineering Geological Observations and Alternatives is shown in Exhibit C.

4.3 Pipe Installation

As stated in previous pages, issues pertaining to having an open channel are water loss, bacteria contamination and unpermitted diversion. These are all impacts to the resource that would be mitigated by closing the ditch and delivering the raw water through a pipeline. This report considered 3 different materials, RCP, Welded HDPE and HDPE ADS N-12 with watertight joint.

4.3.1 Pipe Material

4.3.1.A Reinforced concrete pipe (RCP)

RCP are manufactured with concrete materials that offers strength and durability. It can withstand any fire damage and human vandalism when constructed at grade. Because of its weight, it also eases concerns with hydrostatic uplift pressure. However, installation of RCP requires heavy equipment due to its weight and lead time for the manufacturer as they are built

per project specifics. This type of material is also susceptible to failure caused by downslope creep due to stiffness which make any emergency repair challenging as it requires heavy equipment for replacement or repair. The cost for the installation of RCP including fittings is also a factor as it cost approximately \$170 per linear foot.

4.3.1.B Welded High Density Polyethylene Pipe (HDPE)

Welded HDPE are built with lightweight materials that features extreme strength, durability, flexibility and resistance to chemicals and corrosions. The heat-fused joint creates homogenous, monolithic system that eliminates any concerns with potential leaks. Its lightweight feature significantly improves ease of installation and repair as it does not require heavy equipment to move it on-site. Flexibility of Welded HDPE also allow minor sagging and deformation caused down slope creep minimizing the need for major repairs. However, installation or repair for welded HDPE requires heat fusion equipment for butt-fusing joints and fittings which, due to its remote location, may pose a challenge for Forbestown Ditch application. The estimated cost for the installation of welded HDPE including fittings will also be a factor as it cost approximately \$130 per linear foot.

4.3.1.C HDPE ADS N-12 Pipe with watertight joint

ADS N-12 dual wall pipe comes with its smooth interior wall and corrugated exterior wall which provides durability and hydraulic efficiency. Its integral bell and factory-installed gasket makes it a cost-effective option as it does not require extra coupler, grout or special equipment for installation. Similar to Welded HDPE, lightweight feature of ADS N-12 significantly improves ease of installation as it only requires a few people and does not require heavy equipment. Its flexibility also allows minor sagging and deformation minimizing the need for major repair caused by down slope creep. These materials were used on site during the 2017 emergency repair. The estimated cost for the installation of ADS N-12 including fittings is approximately \$95 per linear foot.

4.3.2 Pipe Installation Method

4.3.2.A Below Grade with 6-inch diameter perforated pipe

This method will have the 42-inch diameter pipe installed within the existing ditch and covered with 2 feet of backfill materials. This will create a wider access road above the pipe for future maintenance and repair of the system. It will also prevent any pipe from being damaged due to fire and/or vandalism. This method of construction, however, requires the backfill materials to be imported from offsite since there are very minimal materials available onsite.

Installation of pipe below grade still requires any water that goes in to the ditch to be drained in order to prevent any issue with hydraulic uplift pressure and soil saturation below the ditch. Perforated pipes and drain rocks can be installed parallel to the HDPE pipe to capture subsurface flow and divert it out of the channel to its natural course at the lower side of the ditch. The cost associated with providing and installing perforated pipe, drain rocks and backfill materials is approximately \$160 per linear foot. Figure 1 shows the Typical Section

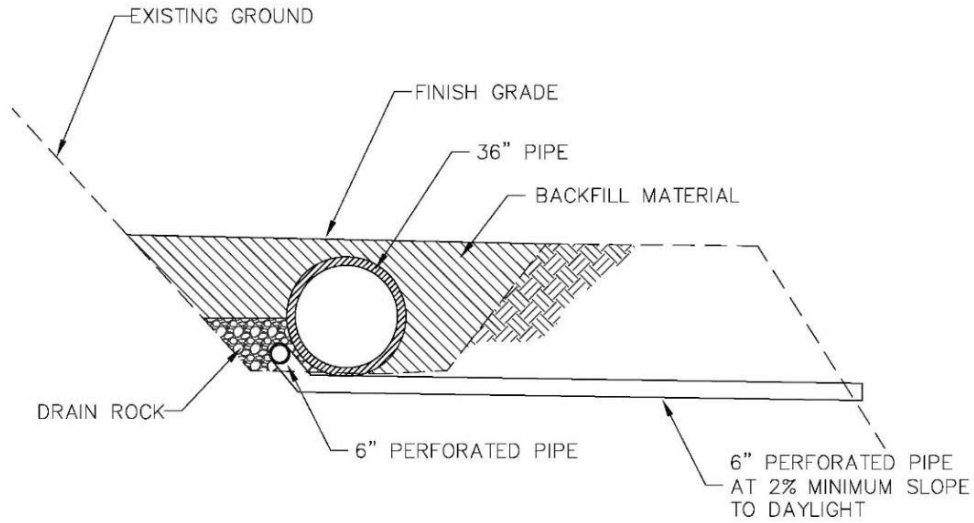

Figure 1

4.3.2.B At-Grade with Pipe Anchor Blocks

This method will have the 42-inch diameter pipe installed at grade and supported by pipe anchor blocks. It will be an advantage for future maintenance and visual inspection of the system. NYWD staff will be able to conduct routine visual inspections of the pipe to detect any maintenance requirements and repairs. Early detection of sagging and deformation of the pipe due to minor soil creep will allow mitigation prior to any major failure. This method, however, will not provide the pipe with any protection against fire damage and vandalism.

Pipe anchor blocks will have a typical dimension of 4-foot-long x 1-foot-wide x 6-inch-high with an insert on each end for pipe strap attachment and installed every 10' to provide a sufficient structural support. The installation of the blocks underneath of the pipe will also provide gap that will allow any surface flow across the pipe without additional excavation. The cost associated with providing and installing the pipe anchor block is approximately \$30 per linear foot. Figure 2 shows the Typical Section.

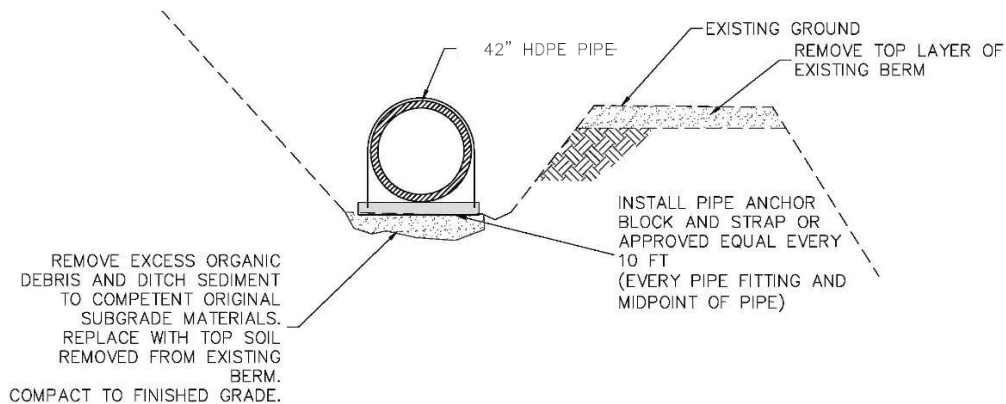

Figure 2

4.3.2.C Below Grade with Pipeline Anchoring System

This method will have the 36-inch and 42-inch diameter pipe installed within the existing ditch and covered with a minimum 1 foot of backfill materials. The system will be anchored to the ground using pipeline anchoring system installed at every 20 ft preventing the pipe from floating caused by hydrostatic uplift pressure. This method is feasible for the lower section to prevent the pipe from being vandalized since it is near the residential areas. It will also prevent any unpermitted pumps from being installed to divert water out of the system.

The pipeline anchors will be designed and sized to handle the loads caused by the uplift pressure eliminating the need for subdrain.

Unlike the upper section of the pipe system, this portion of the project is not expected to experience the un-equal horizontal hydrostatic loading of the pipe that causes the low side berm failure and pipe blow out. This portion of the project is also easily accessible by the heavy equipment which make constructability a non-issue. Figure 3 shows the Typical Section.

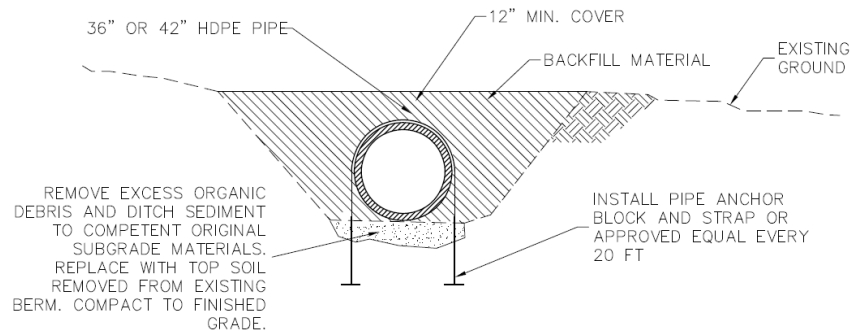

Figure 3

4.3.3 Recommendation

The three different pipe materials considered in this report were reviewed based on constructability, maintenance, ability to withstand downslope creep and cost. It is recommended that HDPE ADS N-12 be used for Forbestown ditch project due to the site being in a remote location with minimal access. The lightweight feature and watertight joint fittings of ADS N-12 will significantly improve ease of installation and future maintenance. Its flexibility feature will also minimize any major failure as it will allow minor sagging and deformation to be repaired prior to any major failure.

The other feature that was considered during the process of selecting the pipe was durability of the pipe against ultraviolet radiation and flammability. In this regard, the durability of RCP outweighs the durability of HDPE pipe. However, cost to benefit ratio associated with materials, placement and maintenance made it viable to select HDPE.

Available upon request is the ADS Inc. drainage handbook Section 4 and supporting documents that covers the durability ADS HDPE pipes.

- **Ultraviolet Radiation**
As stated in the handbook, any product manufactured with plastic materials may degrade overtime if left unprotected from ultraviolet (UV) radiation. ADS incorporated a high-quality UV stabilizer and antioxidant into their polypropylene products to provide additional protection to the pipe and reduce the effect of ultraviolet radiation.
- **Flammability**
Any pipe material including HDPE may be affected by fire if exposed to it. In this scenario, the fire susceptibility of the HDPE was compared to the fire susceptibility of the existing wooden flumes and lack of historical fire damage of the flume. A cost to benefit ratio of the higher cost alternative was also compared to the cost to benefit ratio of HDPE in terms of materials, placement methods and maintenance during the process of selecting ADS N-12. This would apply to post-fire repairs, in that the transport, removal and replacement of damaged sections of HDPE could easily be done by the NYWD crews and equipment, which would not be the case with any other pipe materials.

The proposed method of installation for the upper section (Woodleaf Surge Tower to Costa Creek Siphon inlet) will differ from the proposed method of installation for the lower section (Costa Creek Siphon outfall to the Water Treatment Plant) due to its remote location and different challenges.

The upper section includes installation of 42-inch HDPE ADS N-12 pipe that would be placed within the existing ditch and installed at grade. The pipe will be stabilized with anchor blocks and pipe strap every ten feet for structural support. The Oroleve section will transition to 36-inch HDPE for approximately 2,972 lf.

The lower section will include installation of the 42-inch diameter HDPE ADS N-12 pipe that would be placed within the existing ditch and installed below grade and anchored to the ground using pipeline anchoring system. The anchors will provide support and buoyancy control to the pipe. This portion of the system is also susceptible to vandalism and unpermitted diversion by local landowners which can be mitigated by providing and installing backfill materials.

The comparison for the probable construction cost to install the pipe with backfill material or pipe with anchor blocks is shown on Exhibit D

4.4 Existing Channel Drainage

Historically, there are several surface runoff areas that drain to the existing channel. The surface water from these areas are assumed to introduce bacterial contamination and will not be captured in the conveyance system once the pipes are installed. The surface and subsurface water will continue to flow into the ditch but will be conveyed and released to its natural drainage course by constructing an open conveyance along the access berm allowing the flow to pass under the pipeline without the use of a culvert. The conveyance will have a dimension of 5-foot-wide (bottom) by 1 foot deep with a side slope of 1:1 below the pipe and lined with rock slope protection and geotextile fabric to prevent erosion. An engineered dip will be constructed along the access berm to allow conveyance crossing and still maintain access. The dip will have a 5-foot-wide (bottom) and 3:1 side-slope for an accessible transition. Construction of the conveyance will

prevent the water from ponding in the ditch that causes hydrostatic uplift pressure and soil saturation. Figure 7 shows the Typical Section.

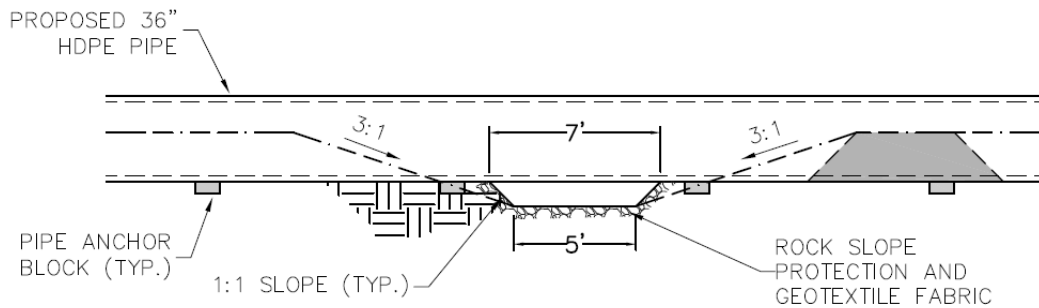

Figure 4

4.4.1-Tributary Drainage

For the areas that are determined to be an upland tributary drainage, flows will be diverted out of the ditch by creating an inlet catch basin at the end of the tributary drainage prior the entering the channel allowing additional volume capacity. The runoffs will then be conveyed by an open conveyance, described above, to cross the pipe and berm releasing tributary runoffs at the lower portion of the berm to its natural drainage course. The locations for the upland tributary drainage will be determined during the final design.

4.4.2 Sheet Flow Drainage

Several areas of the ditch also capture runoffs from the uphill side that sheet flows into the ditch. Swales will be constructed within the ditch to collect any of the surface flows and divert them to open channel downstream. These channels, for the most part, will be constructed at the upstream side of the pipe access port (See Section 5.3) and pipe flow turn out (See Section 5.2) to allow accumulated sheet flow drainage to be turned out to natural drainage course. Other locations determined to require an open channel release surface runoffs will have a four-foot-wide berm/barrier constructed at the downstream side of the channel.

5. MAINTENANCE REQUIREMENTS

Another issue with the existing open channel is the limited access to maintain and repair the existing ditch in the event of any failure. Installation of the proposed pipe system will still require sufficient access for the NYWD to perform inspection and routine maintenance. This concern will be alleviated with the proposed wider maintenance access, pipe flow turn out and pipe access port.

5.1 Maintenance Access

The low side earthen berm exists at its current height to maintain freeboard in the conveyance ditch. During the construction portion of the pipe installation, approximately 2-foot of the top portion of the earthen berm will be excavated and used as the backfill material for the pipe flow

turn out and pipe access port. This will create a wider access road sufficiently enough to allow small pick-up trucks and mini excavators to access to the entire length of the pipe system.

5.2 Pipe Flow Turn out

In an event that any portion of the pipeline requires the water flow to be diverted and released out of the system. Pipe Flow turn out structure will be installed at 5 different locations in the system. This structure will be 50"x50" precast concrete box with two Waterman C-10 canal gate installed at each outlet. The structure will also be covered with native backfill material excavated from the top portion of the berm.

5.3 Pipe Access Port

A pipe access port will be installed throughout the system at approximately 1,000 l.f. increments. This will allow NYWD to access the inside of the pipe for maintenance and observation. The access port will be constructed utilizing an ADS HDPE pipe tee fitting pointing upward to provide continuity within the system and reduce any water flow interruptions. The top will have a cast in place or pre-fabricated concrete frame around the pipe with a lockable diamond plate cover or approved equal. The structure will be covered with native backfill material excavated from the top portion of the berm to prevent any movement.

6. ENVIRONMENTAL REVIEW

NorthStar has prepared an initial biological analysis as well as conducted several field reviews to determine potential impacts associated with the piping of the Forbestown Ditch. Based upon the anticipated project description and field visits, portions of the CEQA/NEPA analysis have been completed. However, because there have been project revisions, preparation of additional studies, the recent re-implementation of the 2015 Clean Water Rule, the required environmental review for the project remains at approximately 76% complete.

In order to complete the biological analysis and CEQA/NEPA documentation an adequate project description that summarizes the whole of the action is required. The project description must include details pertaining to design, construction timing and methods, maintenance and operation of the facility, as well as identification of applicable permits and subsequent agency approvals so that potential impacts can be adequately analyzed.

Given the additional studies, updates to project design details and revisions to the project, per the input from SAGE Engineering and construction contractors, additional environmental analysis is necessary. Specifically, the following project components would need to be evaluated and incorporated into the CEQA/NEPA documentation:

- materials drop off and storage areas
- access routes
- staging areas
- import fill material borrow sites

Therefore, additional time, analysis and budget is required to review the added project components (i.e., staging areas) as well as design details that may result in impacts to cultural,

biological, and water resources. While the additional information adds clarity to the project description and whole of the action, the unanticipated changes have added delays to the completion of the environmental analysis.

7. DESIGN & CONSTRUCTION SCHEDULE

| Task | Duration (months) | Estimated Completion |
|--|------------------------------|---------------------------------|
| DWR Funding Agreement and Contract Execution | 4 | Completed |
| 30% Project Design | 3 | Completed |
| Begin Permitting * | 18 | Completed |
| 60% Project Design | 3 | Completed |
| 90% Project Design | 3 | Completed |
| 100% Project Design | 3 | Completed |
| Final Project Design | 2 | Summer 2019 |
| Permits Acquired and Contract Award | 2 | Fall /Winter 2019 |
| Construction | 36 (3-mobilization) | Spring 2022 |
| Post Construction Activities | 6 | Fall 2023 |

Exhibit A
Location Map

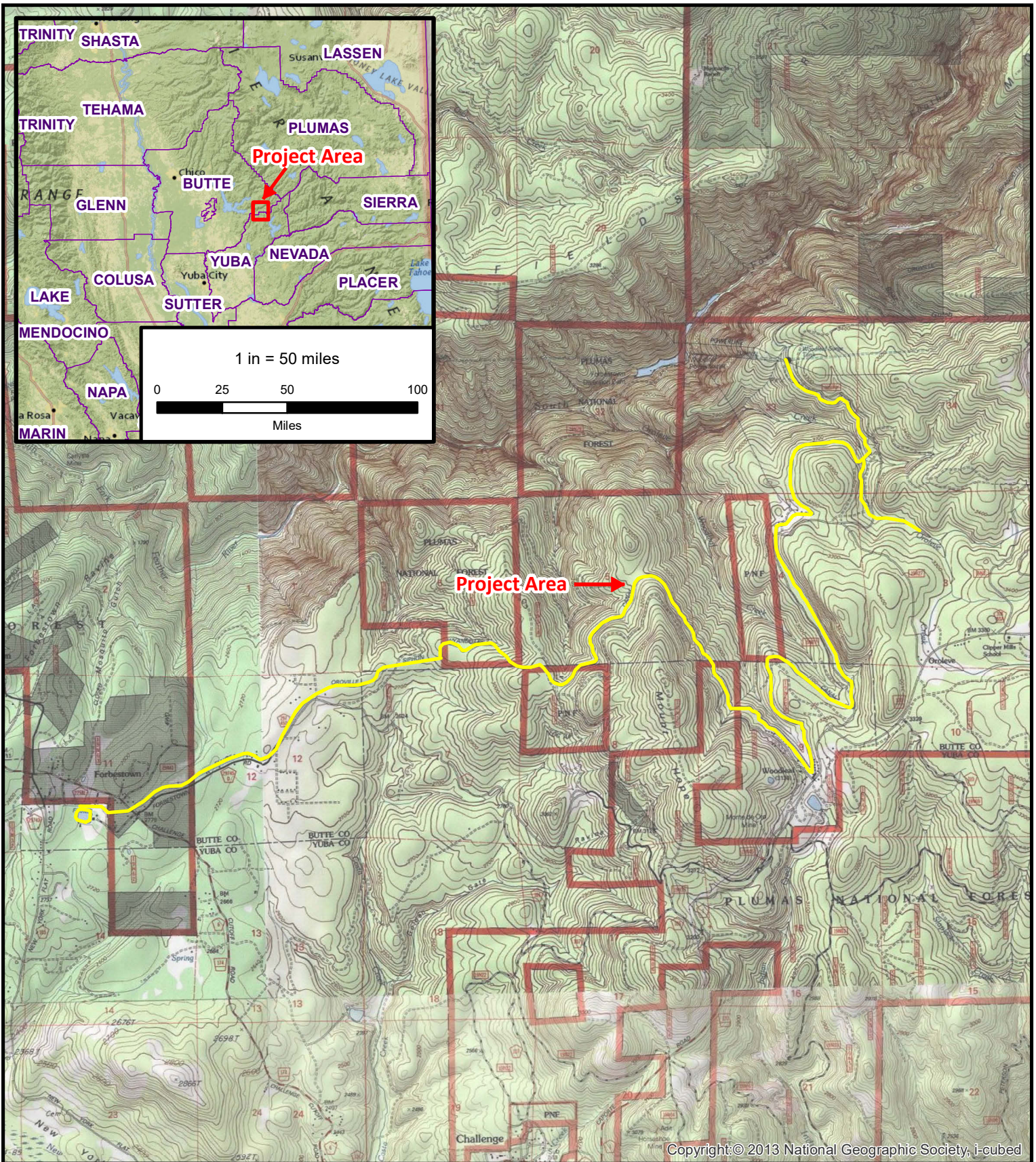

Copyright: © 2013 National Geographic Society, i-cubed

Legend
 — Project Area

Within:
 Sections 33 & 34, T20N, R07E;
 Sections 3-9, T19N, R07E; and
 Section 12, R19N, R06E
 CLIPPER MILLS USGS 7.5' QUAD
 and Sections 11 & 12, T19N, R06E
 FORBESTOWN USGS 7.5' QUAD
 Butte County, CA

Location Map

**Forbestown Ditch Project
 North Yuba Water District
 -Butte County, CA -**

0 0.75 1.5
 Miles

1 in = 0.75 miles (printed at 8 9/23/19)

NORTHSTAR

... Designing Solutions

111 MISSION RANCH BLVD., SUITE 100 CHICO, CA 95926
 PHONE: (530) 893-1600 - www.NorthStarEng.com - © NorthStar

| | | | |
|-----------------|-----------|-----------|-------------------|
| Imagery Source: | Map Date: | Drawn By: | NSE Project # |
| | | | B 19 of 35 17-002 |

Exhibit B

Preliminary Construction Plans

Available at the NYWD Office, 8691 La Porte Rd, Brownsville, CA 95919

Exhibit C

Preliminary Engineering Geological Observation
and Alternatives



December 20, 2017
170036

Mr. Neil Graber, P.E.

NORTHSTAR ENGINEERING, INC.

111 Mission Ranch Blvd, Ste. 100
Chico, CA 95926

**Subject: Preliminary Engineering Geological Observations & Alternatives
Forbestown Ditch Geotechnical Assessment
Forbestown Area, Butte & Yuba Counties, California**

Dear Mr. Graber:

Vertical Sciences, Inc. (VSI), is pleased to present this letter to Northstar Engineering, Inc. (Northstar), providing preliminary engineering geological services for the evaluation of two unstable portions of the North Yuba Water District's (NYWD) existing Forbestown Ditch located in Butte and Yuba Counties, as shown on Plate 1 – Site Location Map. The following letter presents our understanding of the project, our site observations, and possible alternatives for reducing the risk of future movement of slopes in the subject areas of concern

PROJECT UNDERSTANDING

We understand that, historically, a number of failures and areas of distress have occurred along an approximately 5,000-foot long section of the Forbestown Ditch, which have caused that conveyance to fail or come to near failure. These problematic areas are underlain by soils that we understand creep and fail during periods of extended and/or intense rainfall. We understand that during the 2016/2017 winter season, those soils mobilized causing damage to the ditch in at least two primary locations, which are shown on Plate 2 – Areas of Concern. Because of this, we understand that NYWD has retained Northstar to assist in designing alternatives that can be used to provide long-term stability of these problematic areas. In addition, we understand that it is the intent of the NYWD to replace the open ditch conveyance by piping the entire system.

SITE OBSERVATIONS

As noted above, two areas of slope stability concern were identified to VSI as part of this study. Those locations are noted on Plate 2 and described as follows:

- Area 1 – Located near the Oroleve Siphon and south of Oroleve Creek; and
- Area 2 – Located near the Woodleaf Siphon and southwest of Woodleaf Creek.

Observations made at these locations are discussed below.

P.O. Box 491535, Redding, CA 96049
4300 Caterpillar Road, Redding, CA 96003
P & F: (530) 510-4676 ♦ www.VerticalSciences.com

VERTICAL SCIENCES, INC.

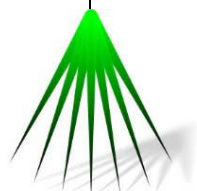



Area 1 Observations

This affected section of the Forbestown Ditch is about 1,000 feet long and is situated on a relatively steep slope with a north-facing aspect. The berm adjacent to the ditch has an uneven grade, implying localized settlement and downslope creep. Localized holes near the slope edge of the berm indicate that erosion due to piping from the ditch has likely occurred.

The ditch in this area is relatively wide compared to most portions of the ditch system and is lined with gunite and/or plastic for long segments of its reach. We understand that the lining materials were placed to reduce the amount of water loss from the ditch into the underlying soils in this area.

The slope above and below the ditch are characterized by gradients ranging from about 80- to more than 100-percent. Shallow slope instabilities were observed locally above the ditch. Numerous pine and conifer trees in this area have deformed trunks (pistol butting) and there are a plethora of oaks, madrone, and other tree species that are often observed on unstable and creeping ground.

Geologic maps of the study area have this section of the ditch mapped extending across undifferentiated diorite and quartz diorite rock materials (Heitanan, 1976), as shown on Plate 3 – Mapped Geological Conditions. Soil survey maps for the area identify the Mariposa Gravelly Loam and underlying the area (NRCS, 2017).

Area 2 Observations

This affected section of the Forbestown Ditch is about 3,800 feet long and is situated on relatively steep slopes with northeast-facing aspects. This section of the ditch is characterized by the presence of numerous flumes and steel pipelines that, we understand, were likely constructed to bridge over unstable areas.

Slopes above and below the ditch are hummocky with numerous benches. Slope gradients varied and appeared to range from about 50- to over 100-percent. Numerous “jack-strawed” and “pistol-butted” trees were observed implying slope movement and creep. There are numerous oaks, madrone, and other tree species that are often observed on unstable and creeping ground. Tension and deformation cracks were observed in soils located below and adjacent to a number of flumes in this area. Locally, some deformation of the flumes was observed.

At the Emergency Repair Site 2, located between about Stations 295+80 and 298+20 (Northstar, 2017), a relatively deep-seated rotational/translational landslide damaged the ditch, necessitating emergency repairs. At this site, tension cracks, scarps, and other geomorphic indicators of slope instability were observed in areas where grading had not removed those features. In addition, groundwater was being discharged from the slope at a number of locations and we understand that subsurface improvements were installed during the repair to capture and divert groundwater.



Geologic maps of the study area have this section of the ditch mapped extending across metarhyolite and metabasalt rock materials (Heitanan, 1976). Soil survey maps for the area identify the Toadtown-Powellton and Sites Gravelly Loam as underlying the northern and southern portions of this area, respectively (NRCS, 2017).

PRELIMINARY CONCLUSIONS REGARDING INSTABILITIES

Area 1 Instabilities

It is our preliminary opinion, based strictly on visual observations, that this area of the ditch is being adversely affected by slope creep and possibly shallow slope failures. The underlying geologic materials are typically relatively stable; however, the soil byproducts can be relatively expansive, contributing to creep. The NRCS (2107) reports these soils as having a Plasticity Index (PI) of about 10, which would correlate to soils with a low expansion potential (Day, 1999); however, the combination of relatively steep slopes and some expansion potential can lead to an adverse slope creep situation, especially when the slope is surcharged by the weight of the berm soils adjacent to the ditch.

Area 2 Instabilities

It is our preliminary opinion, based strictly on visual observations, that this area of the ditch is being adversely affected by rotational and translation slope failures and locally by slope creep. Both metarhyolite and metabasalt typically weather into clay-rich soils. The NRCS (2017) indicates that the underlying soils have PIs ranging from about 19 to 25, which correlate to soils having medium to high expansion potential (Day, 1999). These soils also have clay contents ranging from 36- to 45-percent (NRCS). Soils having high PIs and high clay contents can be very weak, possibly leading to a propensity of slope instabilities, and can be subject to slope creep.

PIPING AND PIPELINE SUPPORT ALTERNATIVE

Based on our conversations with Northstar, we understand that the preferred method for improving the Forbestown Ditch reliability is to install HDPE piping along the ditch's length and support that pipeline at selected horizontal intervals with a pipeline support system installed within the ditch. The pipeline would not be buried but would be exposed within the existing ditch. We understand that the ditch may not be drained (i.e., the berm may remain intact and allow water to pond and flow around the pipeline within the ditch), so to prevent the pipeline from floating, we understand that it will be strapped to the pipeline support. This system should allow visual observation of the pipeline to note sagging or deformation. If sagging or deformation are noted, the piping can be periodically releveled to allow sustained flow of water within the system.

PRELIMINARY ALTERNATIVES FOR REDUCING SLOPE INSTABILITIES

If stabilization of all or portions of the ditch is desired, along with the pipeline and support scenario discussed above, we have provided alternatives that can be used to reduce slope instabilities. A



number of alternatives have been identified to increase slope stability for each area discussed above. The alternatives are based upon the assumption that the water within the ditch will be conveyed by installation of piping along its entire length. It is assumed that the piping will be installed within the existing ditch and that construction measures will be taken to convey water that might be introduced adjacent to and beneath the pipeline onto the slopes below the ditch. Thus, water will not be allowed to channel along or pool within the existing ditch once the pipeline is installed.

Area 1 Alternatives

- **Take no significant action.** This alternative consists of taking no significant actions to improve slope stability aside from installation of the pipeline, as discussed above. The pipeline will have a net benefit of reducing the amount of water introduced to subsurface soils by the existing ditch, which will ultimately increase the stability of the slopes below the ditch. Whether sufficient increases of slope stability will be realized to stabilize this area is unknown. If it is insufficient, then additional slope movement may occur requiring periodic releveling of the pipeline.

There will be no immediate cost impacts from this alternative. However, if continued slope instability occurs, then costs will be experienced in re-establishing grades in this area and possibly repairs to the pipeline.

- **Horizontal Drains.** This alternative consists of installation of horizontal drains to reduce the amount of moisture within creeping and unstable soil materials. Horizontal drains are perforated pipelines that are installed with inclinations of 2 to 5 degrees into slopes to capture and divert water and moisture from those slopes. They are often installed as radial arrays at multiple locations along a slope. Horizontal drains can be effective within rotational and translational landslides, and have less effectiveness with creeping soils; however, some increase in gross stability of creeping soils should be realized using horizontal drains.

For planning-level purposes, horizontal drains should be estimated to cost about \$40 per lineal foot to install. It is anticipated that an array can cover up to about 150 lineal feet of ditch alignment and would consist of six 60-foot long drains per array, or a total of 360 lineal feet of drain per array. Thus, seven total arrays are anticipated to be needed for this alternative, totaling 2,520 lineal feet of drain at a planning-level cost of \$100,800 for installation. Additional costs for contract mobilization/demobilization and access to individual drain locations, would add to the overall cost.

Design-level geotechnical studies should be performed to evaluate the effectiveness of the horizontal drains and to adjust the length of the horizontal drains within the arrays to actual site conditions.



- **Plate Piles.** Installation of plate piles in soil slopes located below the ditch should increase stability of those slopes. Plate piles consist of a proprietary pile system where a flat plate is welded onto a narrow-diameter pipe pile and the plate and pile are driven into the soils in the affected area. These piles can be very effective in reducing or eliminating the effects of slope creep and can stabilize relatively shallow landslides. Typically, the plate piles are installed in a grid pattern using a hydraulic ram affixed to an excavator or mini-excavator. In certain situations, they can be driven using hand-held pneumatic tools.

For planning-level purposes, we've estimated that plate piles will cost about \$250 per pile to install. It is anticipated that a 4-foot by 4-foot grid might be sufficient to increase stability below the ditch. Thus, with three rows of plate piles about 750 plate piles would be needed at a projected cost of \$187,500 to install. Additional costs for contract mobilization/demobilization would add to the overall cost.

Design-level geotechnical studies should be performed to evaluate the effectiveness of the plate piles, to identify the pile length needed, and to adjust grid spacing for the piles below the ditch.

- **Pipeline Supports.** This alternative consists of construction of the pipeline on supports that are constructed below the actively creeping soil zone and able to resist lateral earth forces imposed by the creeping soils. These foundations will be substantial to resist lateral earth pressures. It is anticipated that the supports would need to extend at least 15 feet below grade to resist the lateral forces and be founded below the active soil expansion-contraction zone.

The proposed pipeline will be composed of high-density polyethylene (HDPE). The spacing of the supports will be dependent upon the acceptable free-span distance for the HDPE piping materials unless the pipeline is braced along its axis between pipe supports. For planning purposes, it is estimated that each pipe support will cost at least \$12,000 to construct. If pipe supports are needed at a 5-foot horizontal spacing along the alignment, then a total of 200 supports will be needed at a cost of \$2,400,000. Additional costs for contract mobilization/demobilization would add to the overall cost.

Design-level geotechnical studies should be performed to evaluate the effectiveness of the pipe supports, to identify the minimum depth of foundations, and to adjust the spacing between pipe supports.

- **Soil Nails.** Stabilization of the slope using soil nails might be feasible. Conventionally constructed or launched soil nail arrays could increase the stability of the slope beneath the



ditch if the creep zone depth is relatively shallow. Conventional soil nails are steel rods or tendons installed into a slope then grouted in place. Launched soil nails are steel rods that are launched up to 20 feet deep by using a compressed air canon typically operated by an excavator or larger mini-excavator. The nails are typically installed into the slope at 5 to 20 degrees and in a 5-foot by 5-foot grid pattern. With the launched soil nails, those nails can be hollow and perforated, thus, acting like relatively short horizontal drains.

For planning-level purposes, we've estimated that soil nails will cost about \$1,000 per lineal foot to install. Based on that unit rate, it is anticipated that a projected planning-level cost of \$1,000,000 would be needed for this mitigation if the entire alignment for Area 1 is addressed. It is likely that the actual lineal footage of this alignment can be constrained to less than 1,000 feet during design-level studies, thus, costs would be reduced from that previously noted.

Design-level geotechnical studies should be performed to evaluate the effectiveness of soil nails, to identify the nail lengths needed, and to adjust grid spacing for the soil nails below the ditch.

Area 2 Alternatives

- **Take no significant action.** This alternative consists of taking no significant actions to improve slope stability aside from installation of the pipeline, as discussed above. The pipeline will have a net benefit of reducing the amount of water introduced to subsurface soils by the existing ditch, which will ultimately increase the stability of the slopes below the ditch. Whether sufficient increases of slope stability will be realized to stabilize this area is unknown. If it is insufficient, then additional slope failures may occur requiring periodic releveling and possible reconstruction of the pipeline.

There will be no immediate cost impacts from this alternative. However, if continued slope instability occurs, then costs will be experienced in reestablishing grades in this area and possibly repairing the pipeline.

- **Horizontal Drains.** This alternative consists of installation of horizontal drains to reduce the amount of moisture within creeping and unstable soil materials. Horizontal drains are perforated pipelines that are installed with inclinations of 2 to 5 degrees into slopes to capture and divert water and moisture from those slopes. They are often installed as radial arrays at multiple locations along a slope. Horizontal drains can be very effective with rotational and translational landslides, and have less effectiveness with creeping soils; however, some increase in gross stability of creeping soils will be realized using horizontal drains.



For planning-level purposes, horizontal drains should be estimated to cost about \$40 per lineal foot to install. It is anticipated that an array can cover up to about 150 lineal feet of ditch alignment and would consist of six 60-foot long drains per array, or a total of 360 lineal feet of drain per array. It is not anticipated that the entire Area 2 length would need stabilization. For planning purposes, we've assumed 60-percent of the alignment will need mitigation. Thus, 15 total arrays are anticipated to be needed for this alternative, totaling 5,400 lineal feet of drain at a planning-level cost of \$216,000 for installation. Additional costs for contract mobilization/demobilization would add to the overall cost.

Design-level geotechnical studies should be performed to evaluate the effectiveness of the horizontal drains and to adjust the length of the horizontal drains within the arrays to actual site conditions.

- **Buttress Stabilization.** This alternative consists of performing heavy grading along unstable portions of the alignment to create buttress stabilizations of landslide areas. A buttress stabilization consists of removal of landslide deposits to a targeted depth or through the landslide deposits, installation of subsurface drainage, then reconstruction of the excavated areas with engineered fill to create a buttress against future slope instability. Often, in highly unstable areas, the buttress stabilization has to be constructed in limited reaches to reduce the risk of destabilizing slopes while constructing the buttress.

For planning purposes, we estimated that four, 20-foot deep by 100-long slope failure features would need stabilization. Each location would require excavation of about 2,500 cubic yards (yd³) totaling 10,000 yd³ for all of the assumed locations. For planning-level purposes, we have used a unit rate of \$27 per cubic yard to estimate costs. That rate includes installation of subdrains. Based on that projection, the total estimated planning-level cost for this alternative would be \$270,000. Obviously if more or fewer areas require stabilization then the numbers will need to be adjusted.

Design-level geotechnical studies should be performed to map landslides along this areas alignment, explore and evaluate the subsurface geometries of those landslides, sample and test soils to develop strength criteria, perform geotechnical analyses to evaluate the effectiveness of the horizontal drains and to adjust the length of the horizontal drains within the arrays to actual site conditions.

- **Soil Nails.** Stabilization of the slope using soil nails might be feasible. Conventionally constructed or launched soil nail arrays could increase the stability of the slope beneath the ditch if the creep zone depth is relatively shallow. Conventional soil nails are steel rods or tendons installed into a slope then grouted in place. Launched soil nails are steel rods that



are launched up to 20 feet deep by using a compressed air canon typically operated by an excavator or larger miniexcator. The nails are usually installed into the slope at 5 to 20 degrees with a 5-foot by 5-foot grid pattern. With the launched soil nails, those nails can be hollow and perforated, thus, acting like relatively short horizontal drains.

For planning-level purposes, we've estimated that soil nails will cost about \$1,000 per lineal foot to install. Based on that unit rate, it is anticipated that a projected planning-level cost of \$400,000 would be needed for this mitigation if 400 lineal feet of the alignment is stabilized.

The actual lineal footage of this alignment to be constrained is unknown but can be evaluated during design-level studies. Those geotechnical studies should be performed to evaluate the effectiveness of soil nails, to identify the nail lengths needed, and to adjust grid spacing for the soil nails below the ditch.

CLOSURE

We appreciate the opportunity to propose on this project. If you have questions regarding this proposal or require additional information, please contact me at (530) 638-5263 at your convenience.

Regards,

VERTICAL SCIENCES, INC.

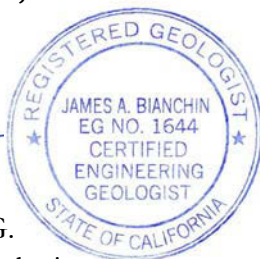

James A. Bianchin, C.E.G.
Principal Engineering Geologist



REFERENCES

Day, R. (1999), Geotechnical and Foundation Engineering, Design and Construction, McGraw – Hill, New York, NY 10121-2298.

Heitanan, A. (1976), Metamorphism and Plutonism Around the Middle and South Forks of the Feather River, California, U.S. Geological Survey Professional Paper 920, Scale 1:48,000.

Northstar Engineering (2017), Emergency Repair, Site 2, Forbestown Ditch, Plan Sheet 1 of 1, Dated February 17.

Natural Resources Conservation Service (2017), Web Soil Survey access on line at <http://websoilsurvey.nrcs.usda.gov/app/HomePage.htm>.



SITE LOCATION MAP

| | |
|---|--------------------------|
| Forbestown Ditch Alternatives Northstar Engineering, Inc. Butte & Yuba Counties, California | Plate No. |
| | 1 |
| 9/23/10 EPGD Plan 6 Attachments P.01 VERTICAL SCIENCES, INC. | Project no. 35 170036 |

Scale undetermined
 Base maps derived from Google Maps.

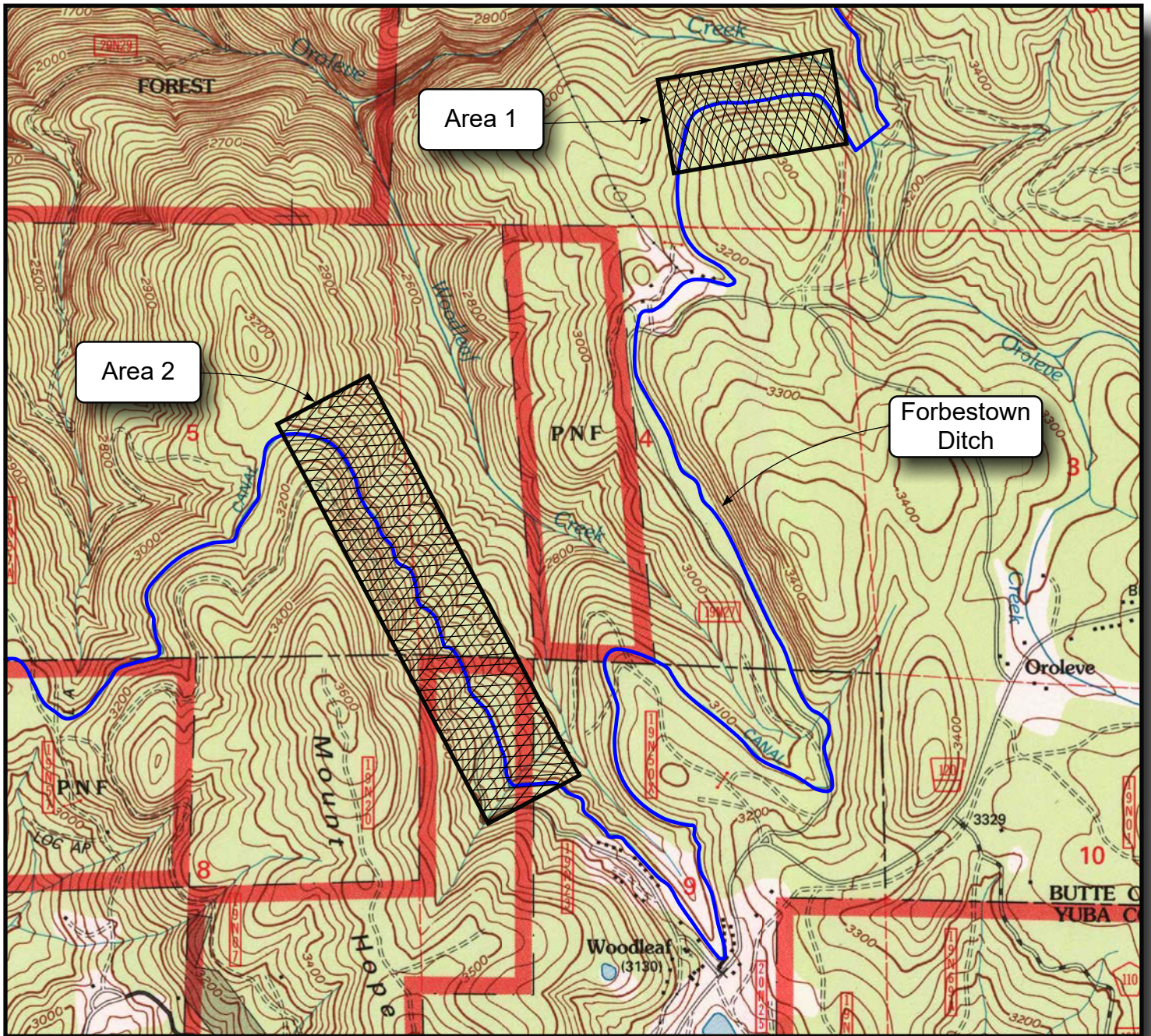

AREAS OF CONCERN

Forbestown Ditch Alternatives
Northstar Engineering, Inc.
Butte & Yuba Counties, California

Plate No.

2

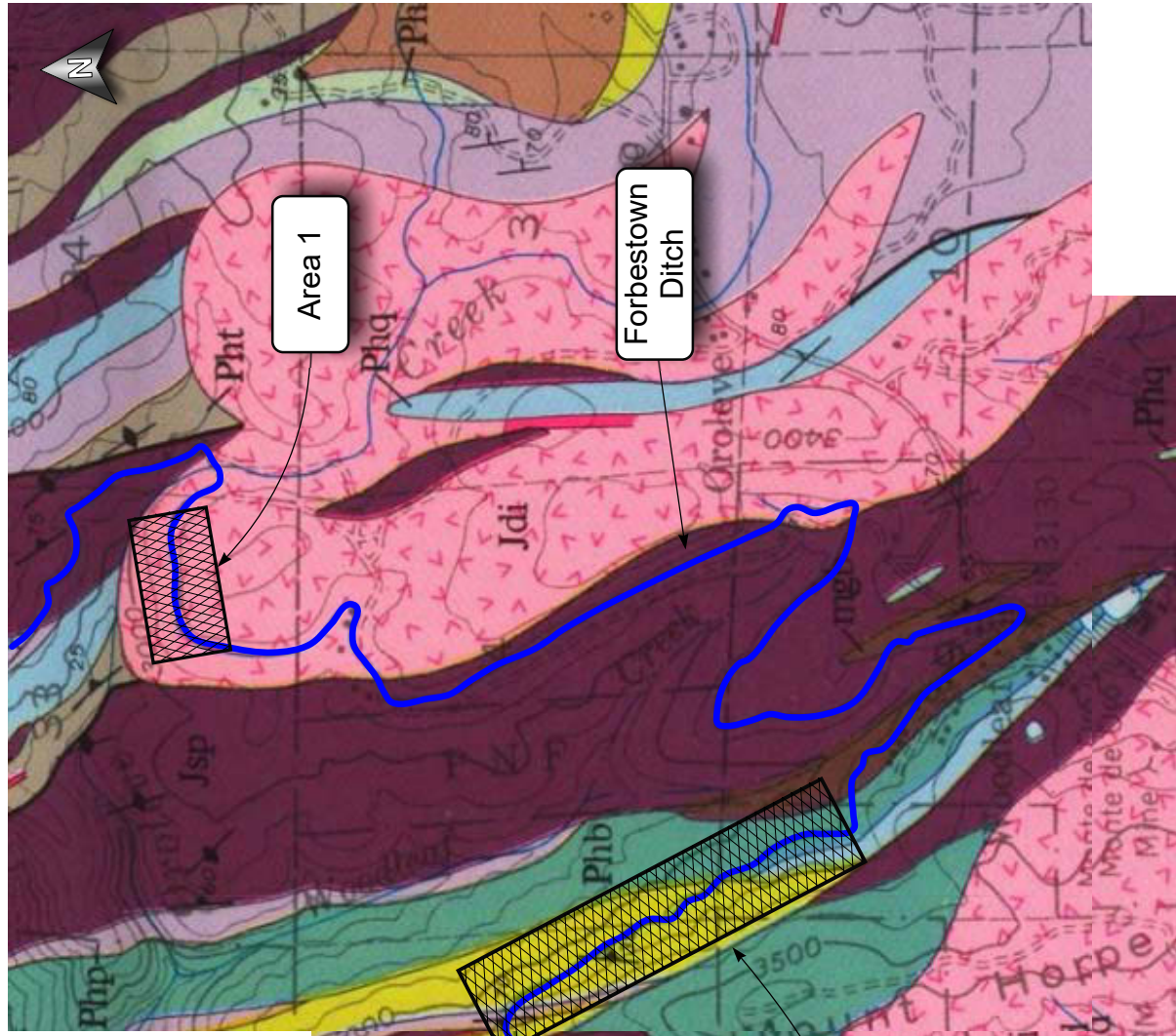

- Metabasalt – Dark-gray to black foliated hornblende-albite rock with some epidote and magnetite
- Meta-andesite – Greenish-gray fine-grained massive to foliated epidote-actinolite-hornblende-albite rock with or without chlorite
- Metadacite – Light-greenish-gray massive to foliated albite-quartz-actinolite-hornblende-epidote rock with or without chlorite
- Metarhyolite – White- to light-gray massive to foliated quartz-albite-biotite-muscovite-epidote rock with some actinolite. Some occurrences are rich in potassium feldspar, some others in biotite
- Metatuff – Foliated rocks consisting of quartz, albite, epidote, and actinolite with varying amounts of hornblende, chlorite, biotite, and muscovite. Color changes with increasing quartz content from dark gray through greenish or brownish gray to white. Includes layers of tuffaceous metasediment
- Marble – White to light-gray partly micaceous calcium carbonate rock with distinct bedding
- Quartzite and metachert, undifferentiated – Quartzite is thin bedded, light bluish gray to white, with some tremolite and micas. Metachert is thin bedded, white to gray, with micaceous laminae or dark gray and massive with white quartz veinlets. Grades to black phyllite
- Phyllite – Brownish-gray fine- to medium-grained foliated rock that consists of quartz, muscovite, biotite, and chlorite with or without epidote and calcite.

| |
|-----|
| Phb |
| Pha |
| Phd |
| Phr |
| Pht |
| Phm |
| Phq |
| Php |

- DIORITE AND QUARTZ DIORITE, UNDIFFERENTIATED – Coarse- to medium-grained gray rock that consists of plagioclase, epidote, and hornblende with some quartz, biotite, and magnetite
- GABBRO – Coarse-grained dark-gray to black rock that consists chiefly of hornblende, plagioclase (An₃₅₋₆₅), epidote, and magnetite
- SERPENTINE AND PERIDOTITE – Peridotite consists of augite, enstatite, olivine, and magnesio-hornblende; partly altered to serpentine, talc schist, and soapstone
- METATRONDHJEMITE – Medium-grained, light-bluish-gray, equigranular, massive to foliated albite-quartz-biotite-hornblende rock with some actinolite, epidote, muscovite, and chlorite
- METADIORITE – Medium-grained, gray, equigranular, massive or slightly foliated rock consisting of hornblende albite, epidote, and quartz
- METAGABBRO AND HORNBLENDITE – Coarse- to medium-grained dark-gray to black equigranular hornblende-plagioclase-epidote rock, in places foliated. Includes masses of coarse-grained hornblende rock

| |
|-----|
| Jdi |
| Jgb |
| Jsp |
| mtr |
| mdi |
| meb |

MAPPED GEOLOGICAL CONDITIONS

| | |
|---|-----------|
| Plate No. | 3 |
| Forbestown Ditch Alternatives Northstar Engineering, Inc. Butte & Yuba Counties, California | |
| Project no. | 35 170036 |
| 9/23/2013 VERTICAL SCIENCES, INC. | |

Exhibit D

Probable Construction Cost

**Forbestown Ditch Project
Project Cost Estimate**

| Bid Item | Item Description | Unit of Measure | Estimated Quantity | Unit Price | Amount |
|----------|---|-----------------|--------------------|---------------|-----------------|
| 1 | Mobilization (3 Mobilizations) | LS | 1 | \$ 300,000.00 | \$ 300,000.00 |
| 2 | Construction Survey | LS | 1 | \$ 60,000.00 | \$ 60,000.00 |
| 3 | Prepare Water Pollution Control Program | LS | 1 | \$ 7,000.00 | \$ 7,000.00 |
| 4 | Clearing, Grubbing and Demolition | LS | 1 | \$ 80,000.00 | \$ 80,000.00 |
| 5 | Erosion Control | LS | 1 | \$ 200,000.00 | \$ 200,000.00 |
| 6 | Construct Upland Tributary Drainage Crossing | EA | 17 | \$ 3,500.00 | \$ 59,500.00 |
| 7 | Open Channel to Pipe transition (Shotcrete) | EA | 2 | \$ 15,000.00 | \$ 30,000.00 |
| 8 | Open Channel to Pipe transition (Quickcrete) | EA | 4 | \$ 4,000.00 | \$ 16,000.00 |
| 9 | Construct Pipe Outlet | EA | 6 | \$ 2,000.00 | \$ 12,000.00 |
| 10 | Modify Siphon Inlet / Outlet Transition | EA | 4 | \$ 15,000.00 | \$ 60,000.00 |
| 11 | Modify Wood Flume | EA | 7 | \$ 10,000.00 | \$ 70,000.00 |
| 12 | Connect HDPE to existing CMP (Marmac coupler) | EA | 4 | \$ 2,500.00 | \$ 10,000.00 |
| 13 | Connect HDPE to existing CMP (Modify concrete headwall) | EA | 2 | \$ 15,000.00 | \$ 30,000.00 |
| 14 | Connect HDPE to existing RCP (Geotextile wrap) | EA | 2 | \$ 3,500.00 | \$ 7,000.00 |
| 15 | Provide and Install Backfill material | CY | 7000 | \$ 100.00 | \$ 700,000.00 |
| 16 | Re-grade Road Crossing w/ Aggregate Base Section | EA | 22 | \$ 4,000.00 | \$ 88,000.00 |
| 17 | Install Pipe Access Port with Frame and Cover | EA | 37 | \$ 3,500.00 | \$ 129,500.00 |
| 18 | Install Pipe flow turn out with 2 slide gate | EA | 7 | \$ 8,000.00 | \$ 56,000.00 |
| 19 | HDPE Plastic Pipe, 36" dia (Oroleve to Oroleve Siphon) | LF | 2972 | \$ 80.00 | \$ 237,777.60 |
| 20 | HDPE Plastic Pipe, 42" dia (Woodleaf Penstock Turnout to Costa Creek Siphon) | LF | 36325 | \$ 100.00 | \$ 3,632,479.00 |
| 21 | HDPE Plastic Pipe, 42" dia (Costa Creek Siphon to Forbestown Treatment Plant) | LF | 7358 | \$ 60.00 | \$ 441,493.20 |
| 22 | HDPE Plastic Elbow Pipe Fitting | EA | 575 | \$ 1,700.00 | \$ 977,500.00 |
| 23 | 18" dia. HDPE Pipe Culvert | EA | 6 | \$ 1,000.00 | \$ 6,000.00 |
| 24 | Existing Water Service Connection | EA | 1 | \$ 1,500.00 | \$ 1,500.00 |
| 25 | Install 36" dia. Pipe Strap and Anchor Block | EA | 300 | \$ 400.00 | \$ 120,000.00 |
| 26 | Install 42" dia. Pipe Strap and Anchor Block | EA | 3640 | \$ 450.00 | \$ 1,638,000.00 |
| 27 | Install 42" dia. Pipe Anchoring System | EA | 370 | \$ 550.00 | \$ 203,500.00 |
| 28 | Construct Sheet Flow Drainage | EA | 5 | \$ 3,000.00 | \$ 15,000.00 |
| 29 | Reset Existing Gate to Finish Grade | EA | 2 | \$ 2,500.00 | \$ 5,000.00 |

| | |
|-------------------|------------------|
| SUBTOTAL | \$ 9,193,249.80 |
| CONTINGENCY (15%) | \$ 1,378,987.47 |
| TOTAL | \$ 10,572,237.27 |



Richard D. Guevarra
R.C.E. 82860

Date: 5-Sep-19